



TECHNISCHES DATENBLATT ÖLPRESSEN-PROGRAMM



KEK TECHNISCHE DATEN P0020

Schneckenpresse	Type:	P0020
Leistung	ca. kg/Std.:	20
Antriebsmotor	kW:	2,2
Netto-Gewicht	ca. kg:	136
Brutto-Gewicht	ca. kg:	171
Kisten-Volumen	ca. m ³ :	0,9
Kisten-Abmessungen	ca. mm B:	1500
	ca. mm H:	810
	ca. mm T:	700

ABMESSUNGEN P0020

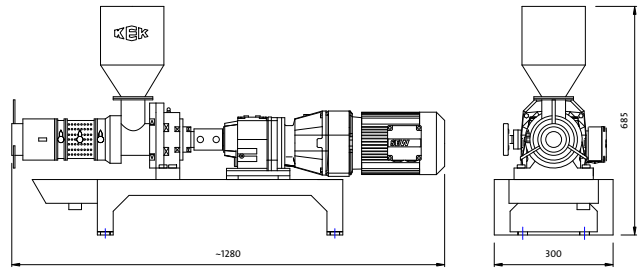

KEK TECHNISCHE DATEN P0101

Schneckenpresse	Type:	P0101
Leistung	ca. kg/Std.:	100
Antriebsmotor	kW:	7,5
Netto-Gewicht	ca. kg:	920
Brutto-Gewicht	ca. kg:	950
Kisten-Volumen	ca. m ³ :	3,7
Kisten-Abmessungen	ca. mm B:	2240
	ca. mm H:	1500
	ca. mm T:	1100

ABMESSUNGEN P0101

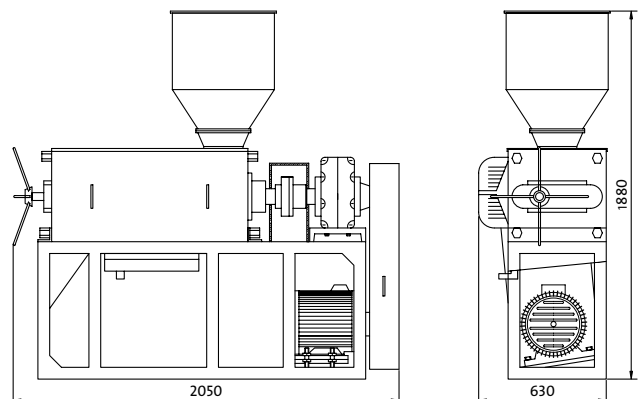



TECHNISCHES DATENBLATT ÖLPRESSEN-PROGRAMM



TECHNISCHE DATEN P0500

Schneckenpresse	Type:	P0500
Leistung	ca. kg/Std.:	500
Antriebsmotor	kW:	22
Netto-Gewicht	ca. kg:	3700
Brutto-Gewicht	ca. kg:	3950
Kisten-Volumen	ca. m ³ :	13,1
Kisten-Abmessungen	ca. mm B:	4060
	ca. mm H:	2030
	ca. mm T:	1590

ABMESSUNGEN P0500

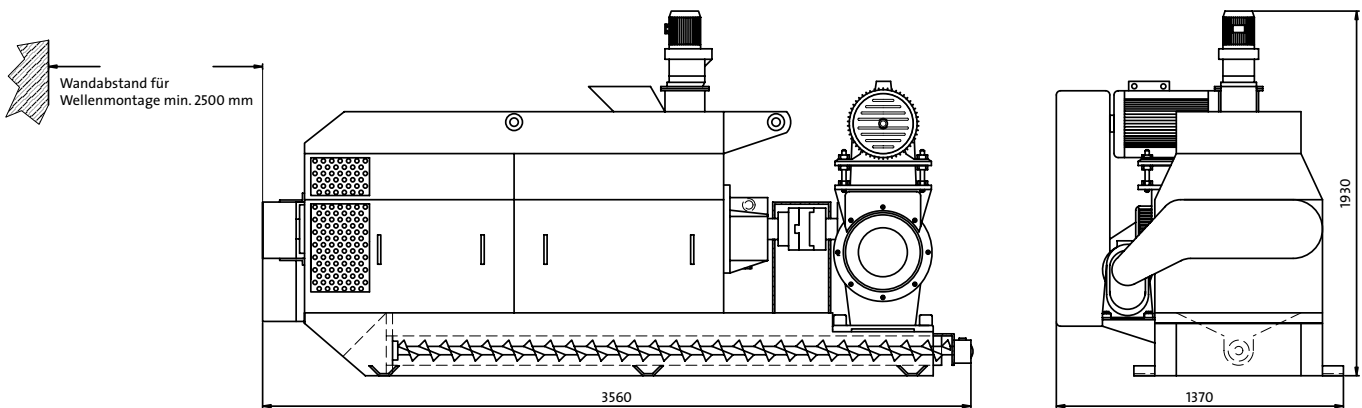

EGON KELLER GMBH & CO. KG

Anton-Küppers-Weg 17
P.O. Box: 140350
D-42824 Remscheid
Germany
Phone +49-2191-84100
Fax +49-2191-8628
Fax +49-2191-8629
E-Mail info@keller-kek.de
www.keller-kek.de